

Application Note

Magnetic Position Sensing in Brushless DC Electric Motors

1.0 INTRODUCTION

This application note discusses regulating the electronic commutation in brushless DC electric motors (BLDC) with the following Honeywell Hall-effect sensor ICs in place of the mechanical commutation used in conventional brush-type DC motors:

- Enhanced digital bipolar (SS30, SS31x/SS41x Series)
- Latching (SS36x/SS46x Series, VF360NT, VF360ST)

BLDC motor technology, coupled with Honeywell’s Hall-effect sensor ICs, provides a cost-effective and reliable alternative to conventional DC motor commutation. Manufacturing and operating cost savings can be realized in several areas:

- Honeywell Hall-effect sensor ICs are relatively low-cost devices
- The low operate and release Gauss levels (at 25 °C ±40 °C) allow the manufacturer to install lower-cost commutation magnetics
- These solid-state sensor ICs have no moving parts to wear out, eliminating maintenance and performance problems created by brush wear and the associated dust.

2.0 OVERVIEW

Brushless DC motors differ from brush-type DC motors in that they employ electronic (rather than mechanical) commutation of the windings.

Figure 1 illustrates how this electronic commutation can be performed by three digital output bipolar or latching sensor ICs. Permanent magnets mounted on the rotor shaft operate the sensor ICs. They communicate the angular position of the shaft to a logic circuit, which encodes this information and controls switches in a driver circuit. The windings then alternate in polarity, in effect rotating in relation to the shaft position. The windings react with the field of the rotor’s permanent magnets to develop the required torque.

Figure 1. BLDC Motor Sensor ICs

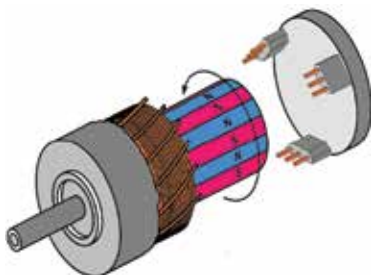

Because no slip rings or brushes are used for commutation, friction, power loss through carbon buildup and electrical noise are eliminated. Electronic commutation also offers greater flexibility in interfacing directly with digital commands.

The long maintenance-free life offered by BLDC motors makes them potentially suitable for applications such as portable medical equipment (kidney dialysis pumps, blood processing equipment, infusion pumps), ventilation blowers for aircraft and marine submersible motors.

3.0 THEORY OF OPERATION

BLDC motors are essentially brush-type motors turned inside out. Power is fed directly to the armature windings, while a permanent magnet rotor is the rotating member. Depending on the design, the motor can be either inner or outer rotating. Also, the brushes and commutator of a classic DC motor are replaced by position sensors and electronic switching.

Torque, the force that produces motion, is developed in DC motors by the permanent magnetic field interacting with the current flowing through the windings. In brush-type motors, the commutator switches the armature windings in order to provide proper magnetic flux and armature current interaction. In brushless motors, a Hall-effect sensor IC detects the position of the rotating magnet and excites the proper windings through logic and driver circuitry.

Many types of BLDC designs are in production today. An eight-pole motor (four pole pairs) with a three-phase winding is shown in Figure 2. Either regular bipolar or latching Hall-effect sensor ICs can be used.

Figure 2. Essential BLDC Motor Elements

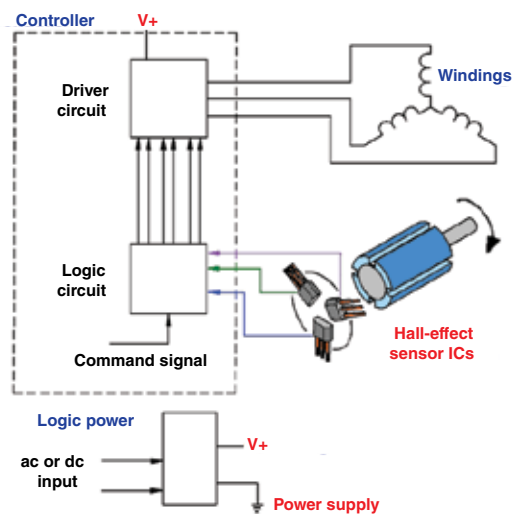

Application Note

Magnetic Position Sensing in Brushless DC Electric Motors

The rotating permanent magnet moving across the front of the sensor IC causes it to change state. The sensor IC operates when each south pole approaches.

Figure 3 shows the output of three sensor ICs placed 30 electrical degrees apart in the BLDC motor. In an eight-pole magnet BLDC motor, each South pole is 90 degrees from the next pole. When three sensor ICs are placed 30 degrees apart, the first sensor IC will operate at 30 degrees, the second at 60 degrees and the third at 90 degrees.

Figure 3. Sensor IC Operation

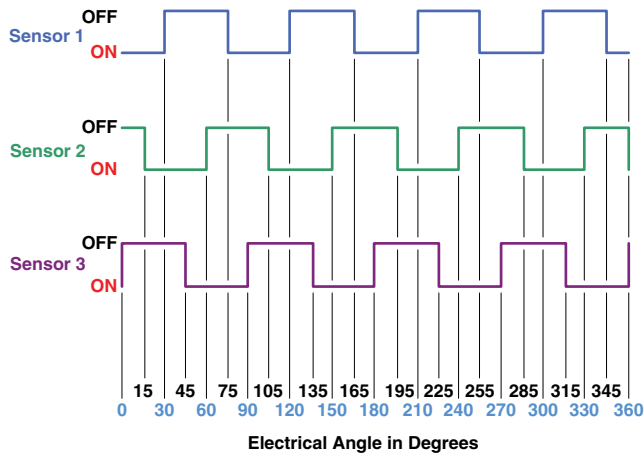

When the North pole passes the sensor ICs, they will release. Each North pole of the rotating eight-pole magnet is 45 degrees from the adjacent South pole. Each sensor IC will release at 45 degrees after operating.

The three sensor IC outputs are used as shaft position encoders. The sensor IC signals magnet position and polarity information to a logic circuit, which switches on power transistors arranged in an “H” bridge formation.

Figure 4 provides an example of a driver circuit using six power transistors and three Hall-effect sensor ICs.

Figure 4. Typical Driver Circuit for Three-phase BLCD Motors

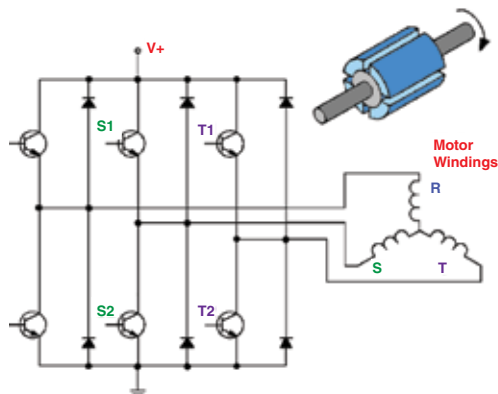

Based on the position of the rotating magnets, each pair of power transistors is correspondingly activated and deactivated, providing current to the armature windings in the appropriate sequence and time.

The sensor ICs can be placed directly inside the motor, at the end of a motor's shaft, or around a ring magnet attached to the rotor shaft, as shown in Figure 5.

Figure 5. Typical Sensor IC Locations

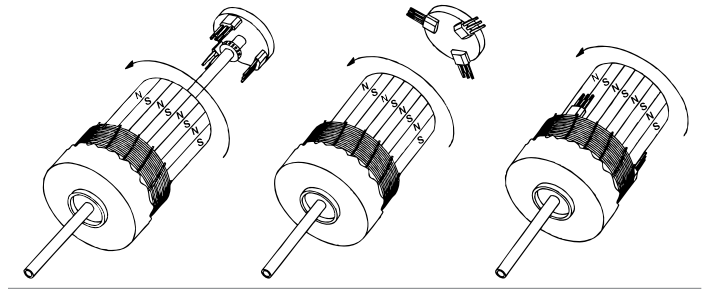

RPM and direction sensing are additional uses for Hall-effect sensor ICs in BLDC motors. Multiple discrete Hall-effect sensor ICs or a single package integrating multiple sensing elements, such as the dual Hall-effect sensor [VF526DT](#), would accomplish these functions. The VF526DT series incorporates two digital Hall-effect elements that provide both speed and direction output.

4.0 HONEYWELL BIPOLAR AND LATCHING HALL-EFFECT SENSOR ICs

Honeywell SS30, SS31x/SS41x and SS36x/SS46x Hall-effect sensor ICs provide the precise motor shaft positioning data needed by BLDC motors. These products include magnetically bipolar or latching sensor ICs, which have positive (South) operate and negative (North) release points that are nearly magnetically symmetrical over the temperature range. A sensor IC operating at positive 90 Gauss, for example, will release at approximately negative 90 Gauss.

4.1 Solution

For reliable, accurate, economical BLDC motor commutation, Honeywell's bipolar or latching Hall-effect sensor ICs listed below would be an excellent choice:

- [SS311PT/SS411P](#) Low-cost Bipolar Hall-Effect Digital Position Sensor in SOT-23 surface-mount or flat TO-92-style through-hole package
- [SS30AT](#) Enhanced Bipolar Hall-Effect Digital Position Sensor in SOT-23 surface-mount package

Application Note

Magnetic Position Sensing in Brushless DC Electric Motors

- **SS361RT, SS461R** Latching Hall-Effect Digital Sensor in SOT-23 surface-mount or flat TO-92-style through-hole package
- **SS361CT, SS461C** High Sensitivity Latching Hall-Effect Digital Sensor IC in SOT-23 surface-mount or flat TO-92-style through-hole
- **SS360NT, SS360ST, SS360ST-10K, SS460S, SS460S-T2** High Sensitivity Latching Digital Hall-Effect Sensor ICs offer a clean output signal and the fastest latch response time in its class. Subminiature SOT-23 surface mount package (SS360NT, SS360ST, SS360ST-10K) or small, leaded, flat TO-92-style package with straight leads (SS460S) or formed leads (SS460S-T2).
- **VF360NT, VF360ST** High Sensitivity Latching Digital Hall-effect Sensor ICs (AEC-Q100 qualification allows for potential use in automotive applications)

For complete electrical and magnetic characteristics, mounting dimensions and operate and release points, visit the Honeywell web site or contact your local Sensing and Productivity Solutions representative.

4.2 Features and Benefits*

- Subminiature package size: SOT-23 Surface-Mount allows highly compact designs
- Low voltage: Operation down to 2.7 V* and reduced current support improve energy efficiency
- Built-in pull-up resistor: Simplifies interfacing
- Built-in reverse voltage protection: Protects sensor IC against damage during assembly
- Robust design for a wide range of applications: Operates up to 150 °C [302 °F]
- High sensitivity: Maximum operate as low as 30 Gauss typical allows use of smaller magnets
- Cost effective: Typically lower cost than traditional Hall-effect sensor ICs

* Specification available in select catalog listings.

Figure 6. Application Cutaway (sensor ICs shown on stationary PC board at the end of the shaft)

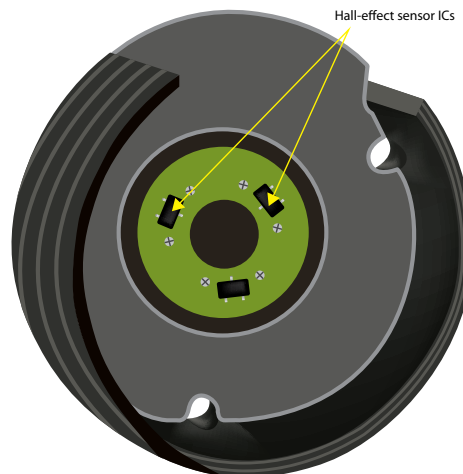

Find out more

To learn more about Honeywell Sensing and Productivity Solutions' products, call +1-815-235-6847 or 1-800-537-6945, visit sensing.honeywell.com, or e-mail inquiries to info.sc@honeywell.com

Sensing and Productivity Solutions
Honeywell
1985 Douglas Drive North
Golden Valley, MN 55422
honeywell.com

Warranty. Honeywell warrants goods of its manufacture as being free of defective materials and faulty workmanship. Honeywell's standard product warranty applies unless agreed to otherwise by Honeywell in writing; please refer to your order acknowledgement or consult your local sales office for specific warranty details. If warranted goods are returned to Honeywell during the period of coverage, Honeywell will repair or replace, at its option, without charge those items it finds defective. **The foregoing is buyer's sole remedy and is in lieu of all warranties, expressed or implied, including those of merchantability and fitness for a particular purpose. In no event shall Honeywell be liable for consequential, special, or indirect damages.**

While we provide application assistance personally, through our literature and the Honeywell web site, it is up to the customer to determine the suitability of the product in the application.

Specifications may change without notice. The information we supply is believed to be accurate and reliable as of this printing. However, we assume no responsibility for its use.

Honeywell