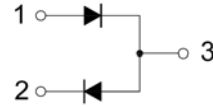
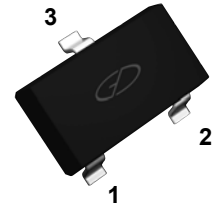


### Features

- High switching speed:  $t_{rr} \leq 4 \text{ ns}$
- Low leakage current
- Small SMD plastic packages
- High stability and high reliability



Schematic Diagram



SOT-23

### Applications

- High-speed switching
- General-purpose switching

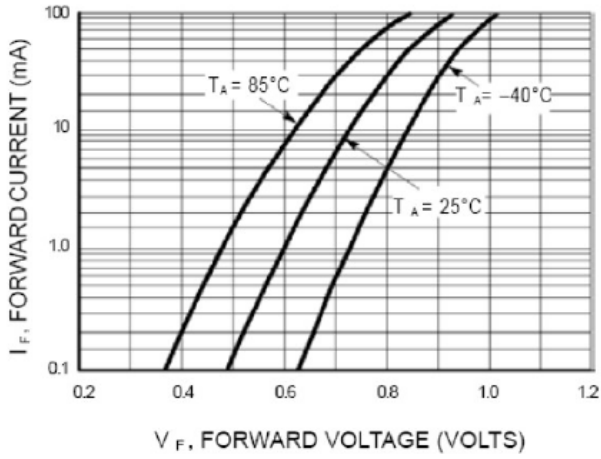
### Absolute Maximum Ratings ( $T_A=25^\circ\text{C}$ unless otherwise noted)

Parameter	Symbol	Max.	Unit
Reverse Voltage	$V_R$	100	V
Peak Repetitive Reverse Voltage	$V_{RRM}$	100	V
Power Dissipation	$P_D$	225	mW
Peak Forward Surge Current	$I_{FM}$	500	mA
Thermal Resistance, Junction-to-Ambient	$R_{\theta JA}$	417	$^\circ\text{C}/\text{W}$
Storage Temperature Range	$T_{STG}$	-55 To +150	$^\circ\text{C}$
Operating Junction Temperature Range	$T_J$	150	$^\circ\text{C}$

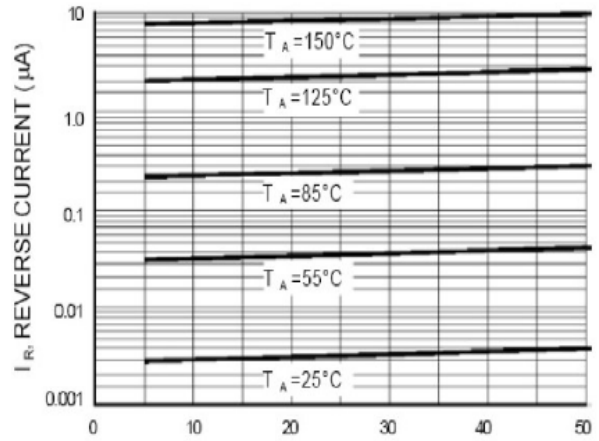
### Electrical Characteristics ( $T_A=25^\circ\text{C}$ unless otherwise noted)

Parameter	Symbol	Conditions	Min.	Max.	Unit
Reverse Voltage	$V_{(BR)}$	$I_R=100\mu\text{A}$	100	-	V
Reverse Leakage Current	$I_R$	$V_R=50\text{V}$	-	1	$\mu\text{A}$
		$V_R=100\text{V}$	-	3.0	
Forward Voltage	$V_F$	$I_F=1\text{mA}$	-	0.72	V
		$I_F=10\text{mA}$	-	0.82	
		$I_F=100\text{mA}$	-	1.1	
Reverse Recovery Time	$T_{RR}$	$I_F=I_R=10\text{mA}$ , $R_L=100\Omega$ , $I_{RR}=0.1I_R$ , $V_R=6\text{V}$	-	4	nS
Capacitance	$C_T$	$V_R=0\text{V}$ , $f=1\text{MHZ}$	-	1.5	pF

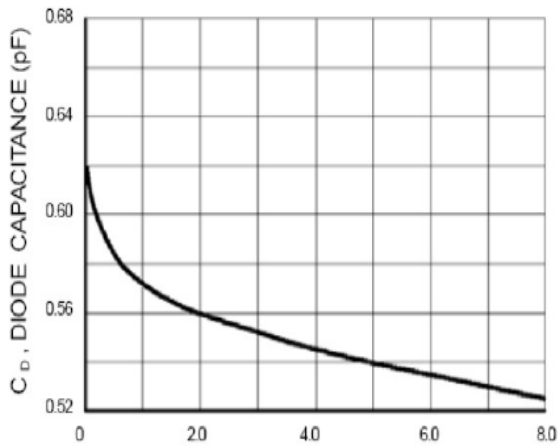
**Ratings and Characteristic Curves**



**Figure 1. Typical Forward Characteristics**

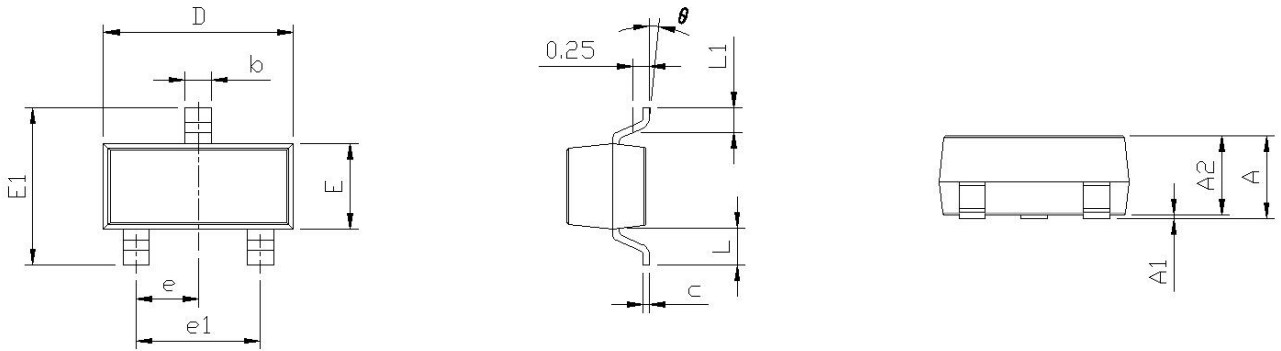


**Figure 2. Typical Reverse Characteristics**



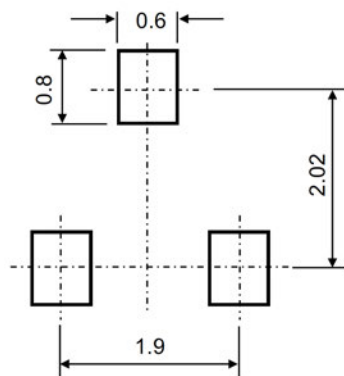
**Figure 3. Typical Capacitance Characteristics**

**Package Outline Dimensions (SOT-23)**



Symbol	Dimensions In Millimeters		Dimensions In Inches	
	Min	Max	Min	Max
A	0.900	1.150	0.035	0.045
A1	0.000	0.100	0.000	0.004
A2	0.900	1.050	0.035	0.041
b	0.300	0.500	0.012	0.020
c	0.080	0.150	0.003	0.006
D	2.800	3.000	0.110	0.118
E	1.200	1.400	0.047	0.055
E1	2.250	2.550	0.089	0.100
e	0.950 TYP		0.037 TYP	
e1	1.800	2.000	0.071	0.079
L	0.550 REF		0.022 REF	
L1	0.300	0.500	0.012	0.020
θ	0°	8°	0°	8°

**Suggested Pad Layout**



Note:  
 1. Controlling dimension: in millimeters.  
 2. General tolerance:  $\pm 0.05\text{mm}$ .  
 3. The pad layout is for reference purposes only.