

# Product change notification

PCN15-01 – KSS – Rev. B

## Document revision

Revision	Date	Description	Author
A	April 10 <sup>th</sup> , 2015	Creation	R.CLEMENT
B	April 23 <sup>rd</sup> , 2015	Correction of a mistake: "Raw material change from PA 4.6 to LCP"	R.CLEMENT

---

## Summary

1. Purpose .....	4
2. Overview .....	4
3. Reason for Change .....	5
4. Part numbers affected .....	6
5. Date of application .....	6
6. Conditions of application .....	6
7. Acknowledgement .....	6
8. Support .....	7

## 1. Purpose

C&K components, as design and manufacturing company for micro-miniature tact switches, is constantly looking to improve the manufacturing means and processes in order to continue serving its customers with the highest performance level.

As part of this continuous improvement policy, C&K Components has engaged a program around the KSS series. This program consists of improvements related to the actuator molding process for KSS series.

## 2. Overview

### KSS2 versions:

- ✓ Injection point: new position
- ✓ Colour: change from brown to white
- ✓ Raw material: change from PA 4.6 to LCP

### Current design

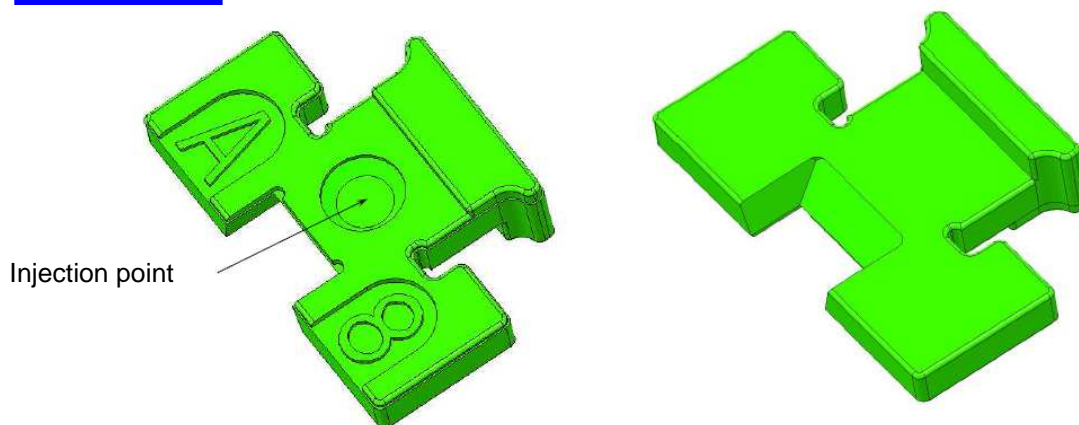

### New design

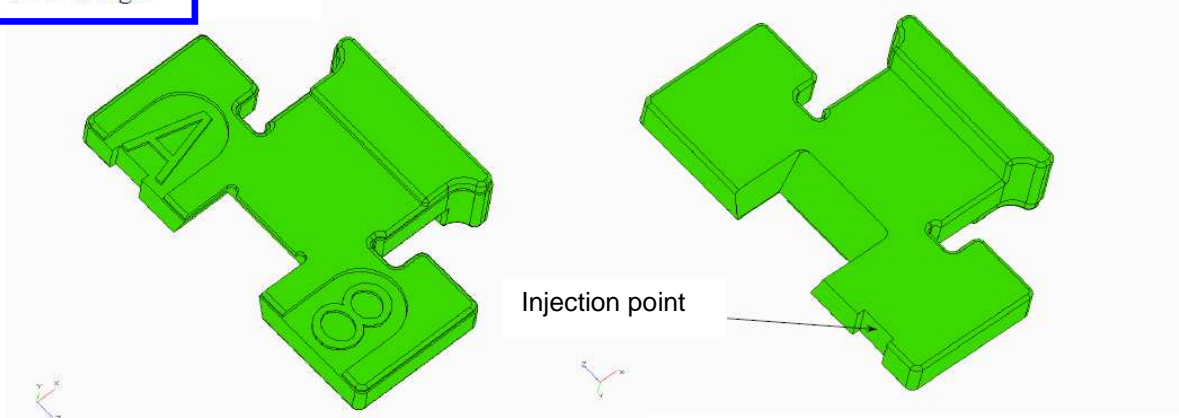

KSS3 versions:

✓ Injection point: new position

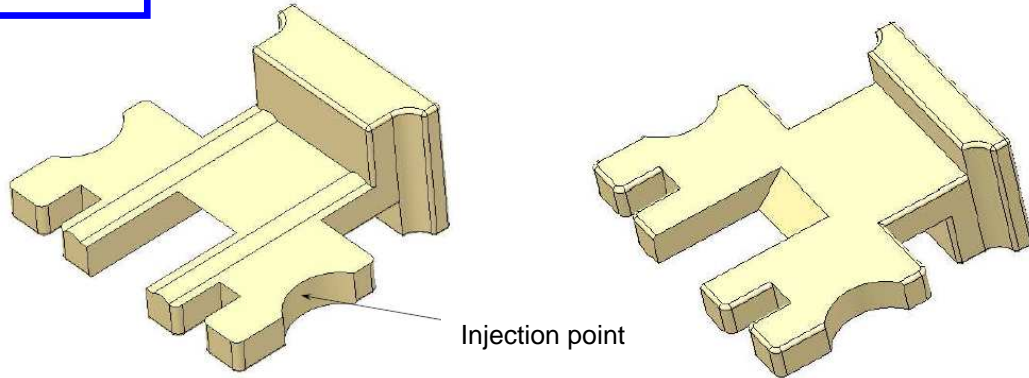
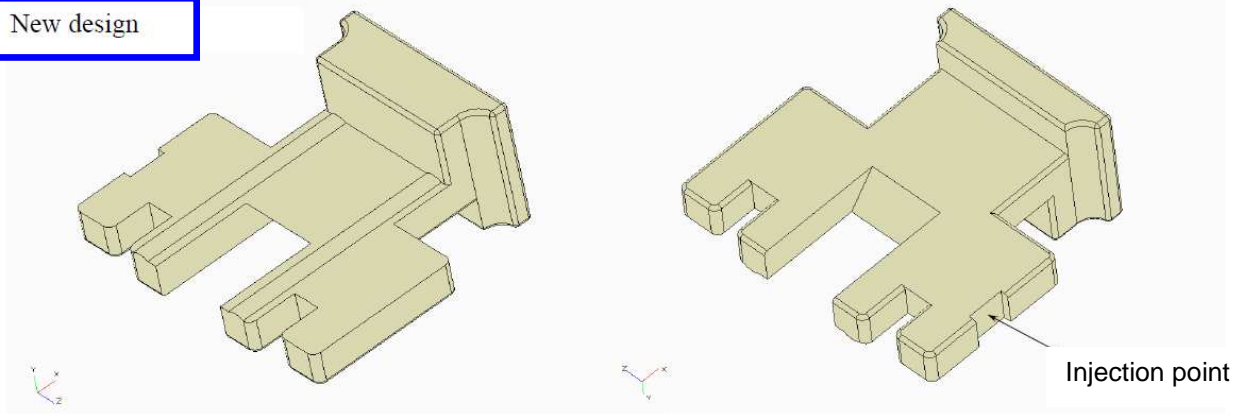
**Current design****New design**

### 3. Reason for Change

#### 3.1 Impact of changes

These evolutions do not change the performances and integration of the switch and therefore, the contents of KSS specifications remain applicable.

#### 3.2 Qualification

Complete re-qualification at C&K

#### 4. Part numbers affected

No modification of current part numbers and designation.

<i>Article</i>	<i>Désignation</i>
Y39A22110FP	KSS221G LFS
Y39A22110FP V46	KSS221G LFS
Y39A22110FPE	KSS221G LFS E
Y39A22111FP	KSS221GH LFS
Y39A22310FP	KSS223G LFG
Y39A22310FPK	KSS223G LFG =S=
Y39A23110FP	KSS231G LFS
Y39A23310FP	KSS233G LFG
Y39A24110FP	KSS241G LFS
Y39A24310FP	KSS243G LFG
Y39A32110FP	KSS321G LFS
Y39A32310FP	KSS323G LFG
Y39A33110FP	KSS331G LFS
Y39A33310FP	KSS333G LFG
Y39A34110FP	KSS341G LFS
Y39A34310FP	KSS343G LFG

#### 5. Date of application

- Samples of the new actuator design version will be available starting W27
- PPAP available starting W28
- Last time buy: Current version will be produced until the **9<sup>th</sup> of October 2015**. After this date, only production with new actuator will be available.
- Last time Delivery: 8 weeks after reception of the last order

#### 6. Conditions of application

Pricing and stock handling policy

\* Pricing: any pricing and other sales conditions remain valid.

\* Stock handling: no obsolescence and no modification are applied on any P/N.

No return or scrap for obsolescence will be accepted.

#### 7. Acknowledgement

For customer requesting PPAP procedure, we recommend to acknowledge this PCN no later than May, 15<sup>th</sup> 2015 at the following e-mail address: [pcn.kss@ck-components.com](mailto:pcn.kss@ck-components.com)

## 8. Support

For any question, please contact your local Sales Representative or the following e-mail address:  
[pcn.kss@ck-components.com](mailto:pcn.kss@ck-components.com)